



PRODUCT SPECIFICATION

TFT-LCD MODULE

Model No: FRD240C24111-A

For Customer's Acceptance	
Approved by	Comment

	Signature	Date
Prepared by	Wang jin	2020.03.30
Checked by	Hu kai	2020.03.30
Approved by	Hu shizheng	2020.03.30

深圳市福瑞达显示技术有限公司

地址: 深圳市光明新区公明田寮第二工业区田荣路 68 号

Add:The 68th,Tianrong Road,Tianliao Community,Gongming Town,Guangming new district,shenzhen.

电话(Tel):0755-23422110

网址(Web):www.fridalcd.com

sales@fridalcd.com



Contents

No.	ITEM
1	Document Revision History
2	General Description
3	Outline Dimension
4	Interface Specification
5	Absolute Maximum Ratings
6	Electrical Specifications
7	Timing Characteristics
8	Power Supply Configuration
9	Optical Specification
10	Inspection Specifications
11	Reliability Test Items
12	Precautions



1. Document Revision History :

DOCUMENT REVISION	DATE	DESCRIPTION	PREPARED BY
A	2020-03-30	First Release.	



2. General Description

No	Item	Specification	Remark
1	Screen Size	2.4 inch	
2	Display Mode	Normally White	
3	Resolution	240 × RGB × 320	
4	Active Area	36.72*48.96	mm
5	Outline Dimension	42.72*59.46*2.3	mm
6	Viewing Direction	12 o'clock	
7	Driver IC	ST7789V2-G4-A	
8	Interface	MCU16Bit	
9	Back Light	White Led*4	
10	Touch Panel	-	

3. Outline Dimension

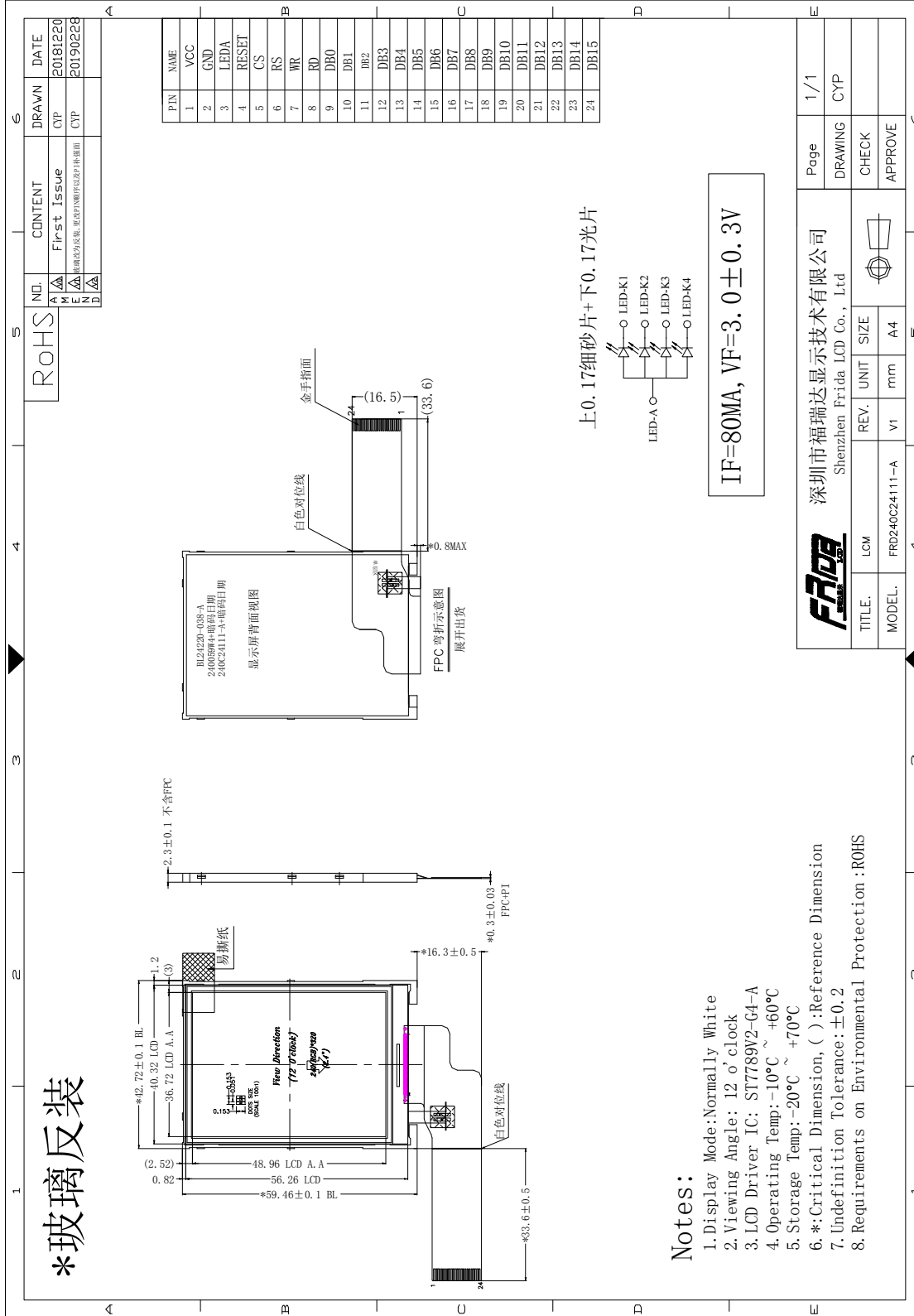



4. Interface Specification

Pin No	Symbol	Description	Note
1	VCC	Power Supply For LCD.	
2	GND (LEDK)	Ground (Power supply Cathode input for backlight)	NOTE1
3	LEDA	Power Supply For LED Backlight Anode Input.	
4	RESET	Reset signal input Pin	
5	CS	Chip selection signal.	
6	RS	Data / Command Selection pin.	
7	WR	Write strobe signal.	
8	RD	Read strobe signal.	
9~24	DB0-DB15	MCU parallel interface data bus.	

Note1: LEDK connect to GND

5. Absolute Maximum Ratings

Electrical Maximum Ratings – for IC Only

Parameter	Symbol	Min.	Max.	Unit	Note
Power supply voltage (VCC)	VCC	-0.3	+4.6	V	1

Note:

- 1.VCC, GND must be maintained.
- 2.The modules may be destroyed if they are used beyond the absolute maximum ratings.

6. Electrical Specifications

At Ta = 25 °C, VCC = 2.4V to 3.3V, GND=0V.

Parameter	Symbol	Conditions	Min.	Typ.	Max.	Unit
Supply voltage (analog)	VCC-GND		2.4	2.8	3.3	V
Supply current (Logic & LCD)	ICC		-	-	-	mA
Supply voltage of white LED backlight	VLED	Forward current =80mA Number of LED = 4	2.7	3.0	3.3	V

7.Timing Characteristics

7.1. 8080 Series MCU Parallel Interface Characteristics: 18/16/9/8-bit Bus

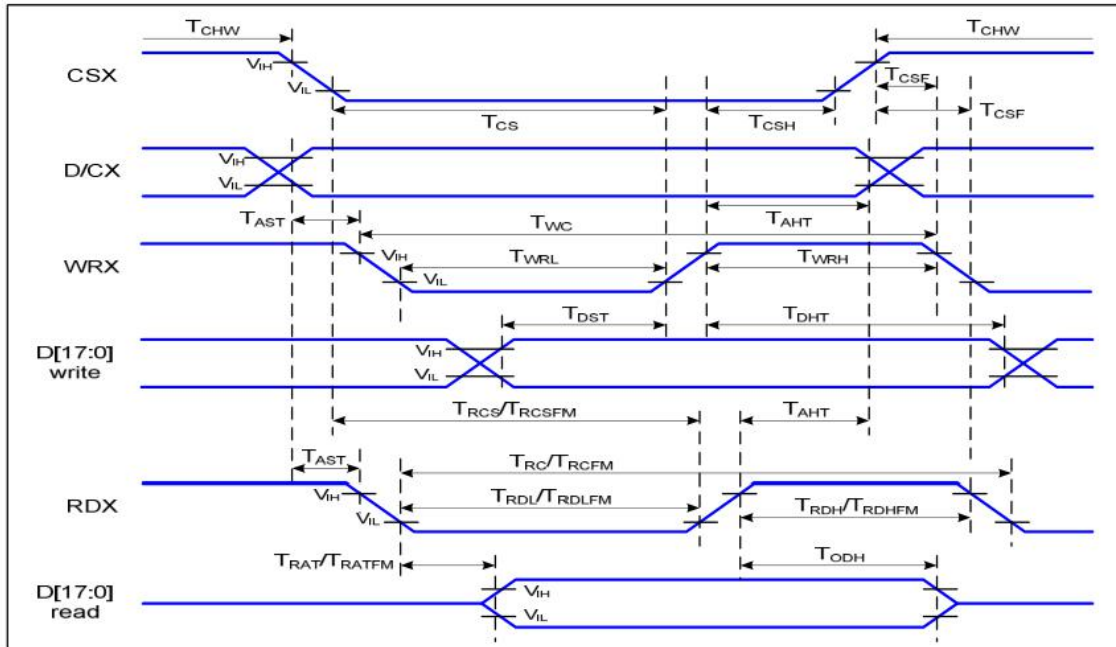

Figure 1 Parallel Interface Timing Characteristics (8080-Series MCU Interface)

VDDI=1.65 to 3.3V, VDD=2.4 to 3.3V, AGND=DGND=0V, Ta=25°C

Signal	Symbol	Parameter	Min	Max	Unit	Description
D/CX	T _{AST}	Address setup time	0		ns	
	T _{AHT}	Address hold time (Write/Read)	10		ns	
CSX	T _{CHW}	Chip select "H" pulse width	0		ns	
	T _{CS}	Chip select setup time (Write)	15		ns	
	T _{RCS}	Chip select setup time (Read ID)	45		ns	
	T _{RCSFM}	Chip select setup time (Read FM)	355		ns	
	T _{CSF}	Chip select wait time (Write/Read)	10		ns	
	T _{CSH}	Chip select hold time	10		ns	
WRX	T _{WC}	Write cycle	66		ns	
	T _{WRH}	Control pulse "H" duration	15		ns	
	T _{WRL}	Control pulse "L" duration	15		ns	
RDX (ID)	T _{RC}	Read cycle (ID)	160		ns	When read ID data
	T _{RDH}	Control pulse "H" duration (ID)	90		ns	
	T _{RDL}	Control pulse "L" duration (ID)	45		ns	
RDX (FM)	T _{RCFM}	Read cycle (FM)	450		ns	When read from frame memory
	T _{RDHFM}	Control pulse "H" duration (FM)	90		ns	
	T _{RDLFM}	Control pulse "L" duration (FM)	355		ns	
D[17:0]	T _{DST}	Data setup time	10		ns	For CL=30pF

T_{DHT}	Data hold time	10		ns
T_{RAT}	Read access time (ID)		40	ns
T_{RATFM}	Read access time (FM)		340	ns
T_{ODH}	Output disable time	20	80	ns

Table 4 8080 Parallel Interface Characteristics

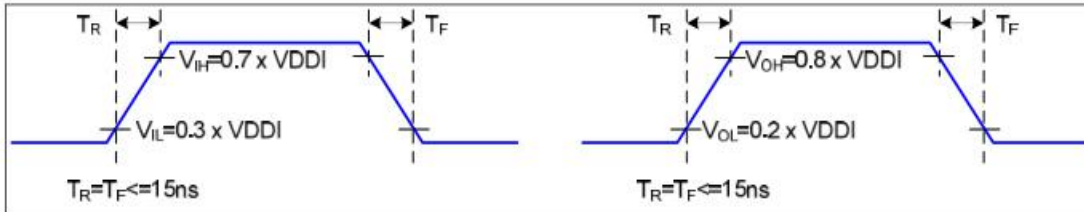

Figure 2 Rising and Falling Timing for I/O Signal

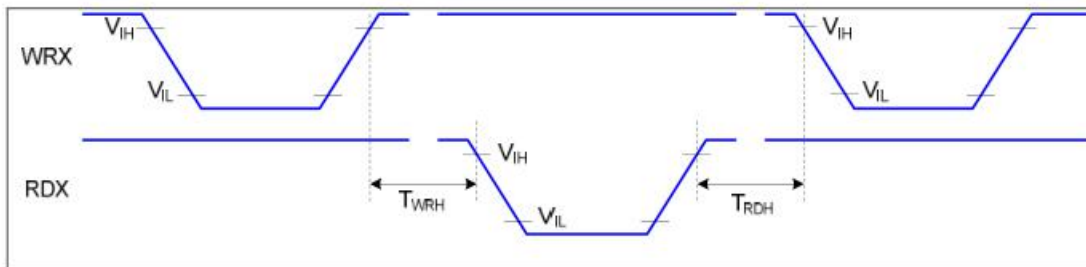

Figure 3 Write-to-Read and Read-to-Write Timing

Note: The rising time and falling time (T_r , T_f) of input signal and fall time are specified at 15 ns or less. Logic high and low levels are specified as 30% and 70% of VDDI for Input signals.

8.Power Supply Configuration

VDDI and VDD can be applied in any order.

VDD and VDDI can be power down in any order.

During power off, if LCD is in the Sleep Out mode, VDD and VDDI must be powered down minimum 120msec after RESX has been released.

During power off, if LCD is in the Sleep In mode, VDDI or VDD can be powered down minimum 0msec after RESX has been released.

CSX can be applied at any timing or can be permanently grounded. RESX has priority over CSX.

Note 1: There will be no damage to the display module if the power sequences are not met.

Note 2: There will be no abnormal visible effects on the display panel during the Power On/Off Sequences.

Note 3: There will be no abnormal visible effects on the display between end of Power On Sequence and before receiving Sleep Out command. Also between receiving Sleep In command and Power Off Sequence.

Note 4: If RESX line is not held stable by host during Power On Sequence as defined in the sequence below, then it will be necessary to apply a Hardware Reset (RESX) after Host Power On Sequence is complete to ensure correct operation. Otherwise function is not guaranteed.

The power on/off sequence is illustrated below

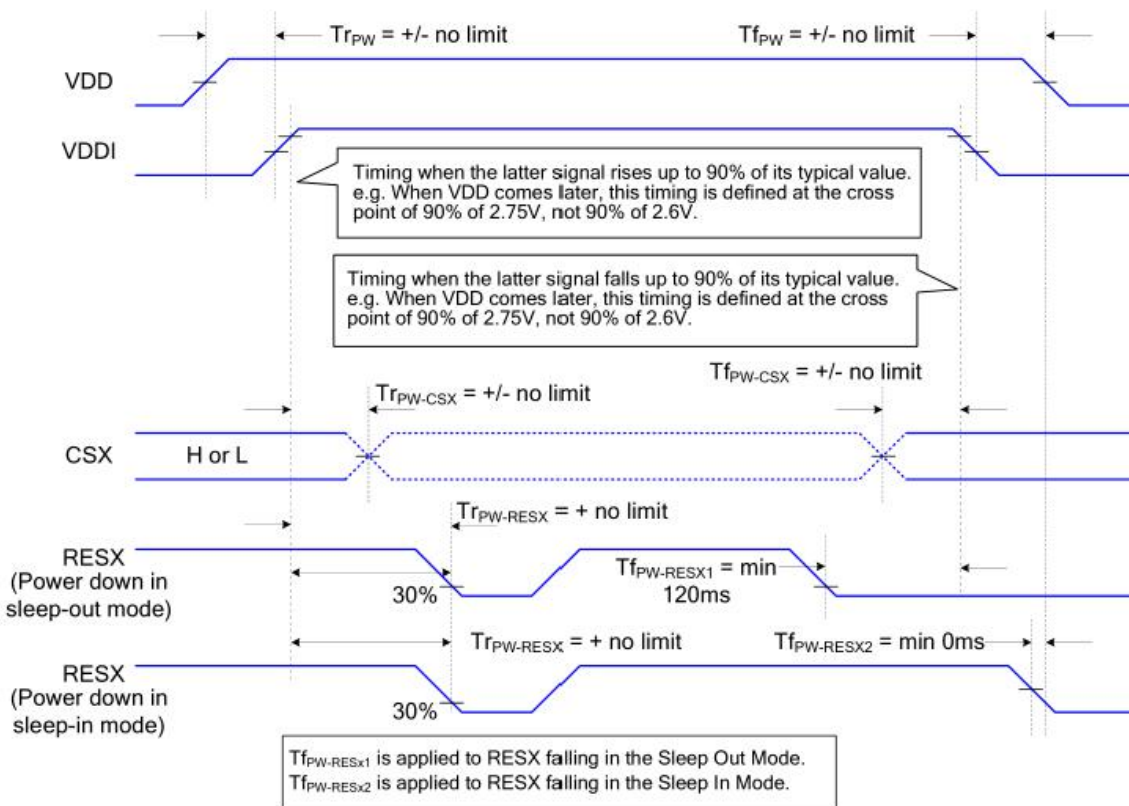



9.Optical Specification

Item 项目	Symbol 符号	Condition 条件	Min 最小值	Typ 典型值	Max 最大值	Unit 单位	Note 备注
Response time 响应时间	Tr+Tf	$\Theta=0^{\circ}$ $\varnothing=0^{\circ}$ Ta=25°C	-	30		ms	1
Contrast ratio 对比度	Cr		-	250	-	-	2
Color gamut 饱和度	S(%)		-	55	-	%	-
Luminance uniformity 均匀度	δ WHITE		80	-	-	%	3
Viewing angle range 视角范围	Θ_{x+}	CR \geq 10 Ta=25°C	-	45	-	deg	4
	Θ_{x-}		-	45	-	deg	
	Θ_{y+}		-	45	-	deg	
	Θ_{y-}		-	20	-	deg	
LCM Luminance LCM 亮度	Lv	$\Theta=0^{\circ}$ $\varnothing=0^{\circ}$ Ta=25°C	-	400	-	Cd/m ²	5

Note1. Response time is the time required for the display to transition from White to black(Rise Time,Tr)and from black to white(Decay Time,Tf).For additional information see FIG1...

Note2.contrast Ratio(CR) is defined mathematically by the following formula ,For more information see FIG2.

Contrast Ratio(CR)=Average Surface Luminance with all white pixels/ Average Surface Luminance with all black pixels

Note3.The uniformity in surface luminance(WHITE) is determined by measuring luminance at each test position,and then dividing the maximum luminance of all white pixels by minimum luminance of all white pixels,For more information seeFIG2.

WHITE=Minimum Surface Luminance with all white pixels(P1,P2,.....)/Maximum Surface Luminance with all white pixels(P1,P2,.....)

Note4.Viewing angle is the angel at which contrast ratio is greater than a specific value.For TET module,the specific value of contrast ratio is 10.For monochrome and color stn module,the specific value of contrast ratio is2.The angles are determined for the horizontal or x axis and the vertical or y axis with respect to the z axis which is normal to the LCD surface.For more information see FIG3

Note5. Surface luminance is the LCD surface luminance with all white pixels,For more information see FIG2.

LV=Average Surface Luminance with all white pixels(P1,P2,.....)

FIG1. The definition of Response time

响应时间定义

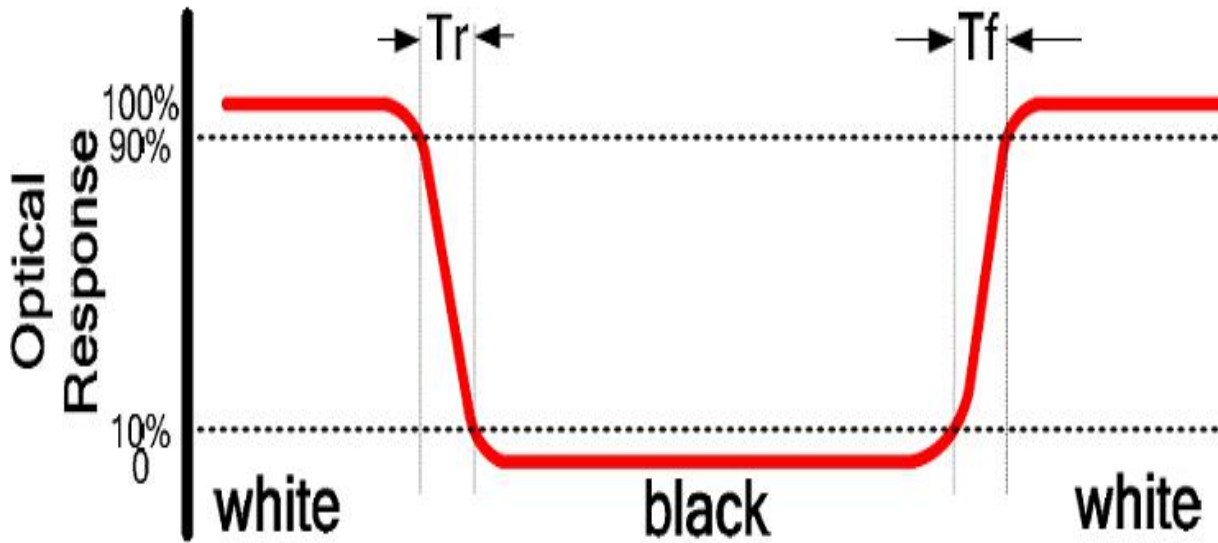

FIG2. Measuring method for Contrast ratio,surface luminance,Luminance uniformity,CIE(X,Y)chromaticity.

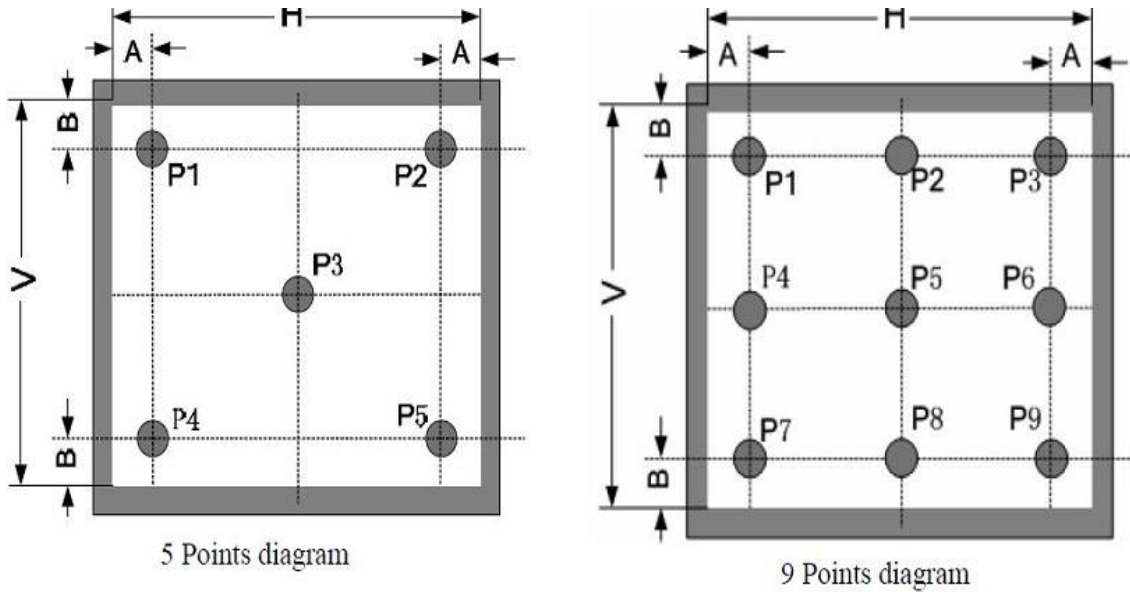
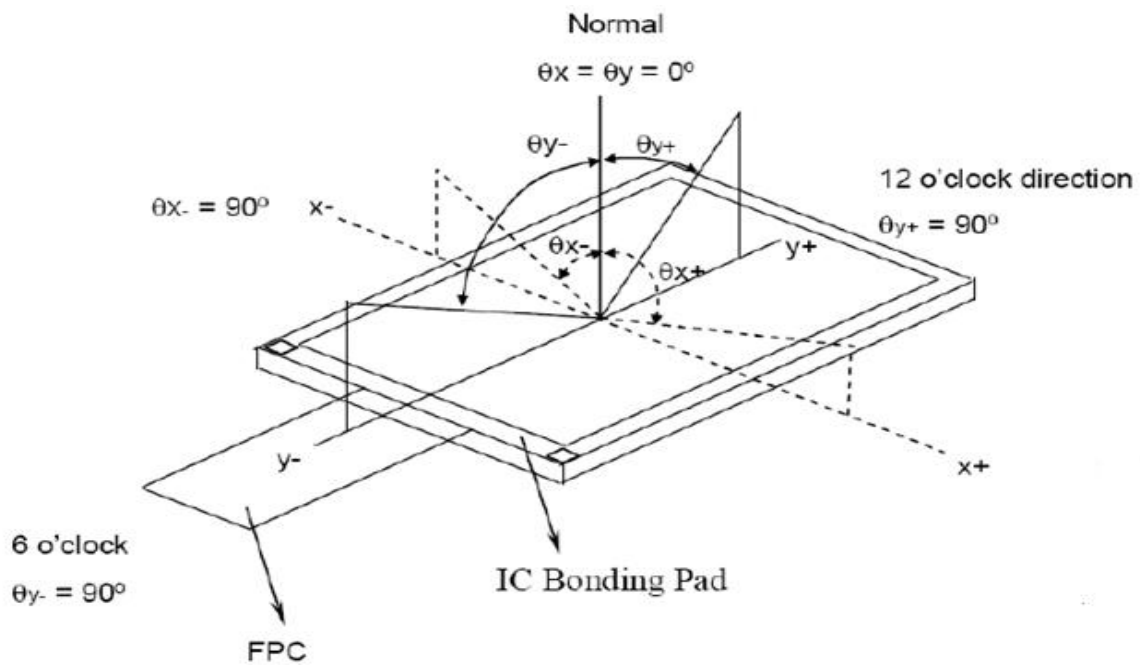

FIG3 The definition of viewing angle 视角定义



10. Inspection Specifications

10.1 Appearance inspection

Item	Acceptable standards for defects	Defect level
Broken	Not allowed	critical defects
Cracks	Not allowed	critical defects
Insufficient UV glue entering	Not allowed	critical defects
Liquid crystal seal leakage	Not allowed	critical defects
Liquid crystal bubbles	Not allowed	critical defects
Surface scratch(mm)	$W \leq 0.02$, ignored	minor defects
	$0.02 < W \leq 0.03$ $L \leq 2, N \leq 2$	
	$0.03 < W \leq 0.05$ $L \leq 1, N \leq 1$	
	$0.05 < W$ Not allowed	
Black/white spot(mm)	$D \leq 0.1$, ignored; $0.1 < D \leq 0.15, N \leq 4$	minor defects
	$0.15 < D \leq 0.2, N \leq 2$; $0.2 < D$, Not allowed	
The seal pollution	Not allowed	minor defects
Liquid crystal residues	Not allowed	minor defects
Surface stains	Stains that cannot be cleaned or erased are not allowed	minor defects
size	Refer to the product specification corresponding to each product, overall size(including length, Width, thickness) or partial size exceeding the drawing size is not allowed	major defects

Remarks : 1)Surface scratches within 1.5mm of the glass edge are ignored;

2) D = diameter, L = length, W = width, N = qty;

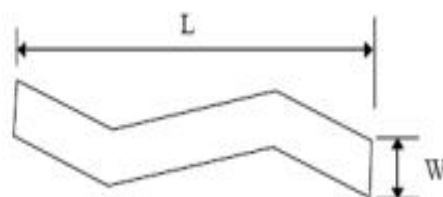
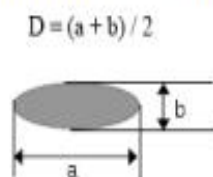

10.2 Functional test criteria

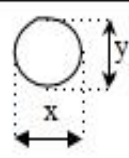
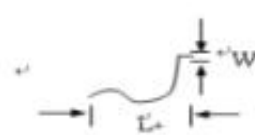
Item	Judgment	Level																			
Display status	No Display、Incomplete image、line defect、wrong viewing angle、flickering、abnormal image、are not allowed	major defects																			
	Display color, judged by approved samples, Or by limited samples	minor defects																			
	MURA or the phenomenon that is unable to describe in words, judged by ND 5% or limited samples	minor defects																			
Spot(bright/dark) defect	Definition of spot defect: $\Phi = (x+y) / 2$ 	minor defects																			
	<table border="1"> <thead> <tr> <th rowspan="2">Size(mm)</th> <th colspan="2">acceptable qty</th> </tr> <tr> <th>Active area</th> <th>View area</th> </tr> </thead> <tbody> <tr> <td>$\Phi \leq 0.1$</td> <td colspan="2">ignored</td> </tr> <tr> <td>$0.1 < \Phi \leq 0.15$</td> <td colspan="2">2 (gap ≥ 5)</td> </tr> <tr> <td>$0.15 < \Phi \leq 0.2$</td> <td colspan="2">1</td> </tr> <tr> <td>$0.2 < \Phi$</td> <td colspan="2">Not allowed</td> </tr> </tbody> </table>		Size(mm)	acceptable qty		Active area	View area	$\Phi \leq 0.1$	ignored		$0.1 < \Phi \leq 0.15$	2 (gap ≥ 5)		$0.15 < \Phi \leq 0.2$	1		$0.2 < \Phi$	Not allowed			
	Size(mm)			acceptable qty																	
			Active area	View area																	
	$\Phi \leq 0.1$		ignored																		
	$0.1 < \Phi \leq 0.15$		2 (gap ≥ 5)																		
$0.15 < \Phi \leq 0.2$	1																				
$0.2 < \Phi$	Not allowed																				
Black/white line	Definition of line defect: L: length, W: width 	minor defects																			
	<table border="1"> <thead> <tr> <th colspan="2">Size(mm)</th> <th colspan="2">Acceptable qty</th> </tr> <tr> <th>W(width)</th> <th>L(length)</th> <th>Active area</th> <th>View area</th> </tr> </thead> <tbody> <tr> <td>$W \leq 0.03$</td> <td>ignored</td> <td>ignored</td> <td rowspan="2">ignored</td> </tr> <tr> <td>$0.03 < W \leq 0.05$</td> <td>$L \leq 2.0$</td> <td>3</td> </tr> <tr> <td>$W > 0.05$</td> <td>-</td> <td colspan="2">Not allowed</td> </tr> </tbody> </table>		Size(mm)		Acceptable qty		W(width)	L(length)	Active area	View area	$W \leq 0.03$	ignored	ignored	ignored	$0.03 < W \leq 0.05$	$L \leq 2.0$	3	$W > 0.05$	-	Not allowed	
	Size(mm)		Acceptable qty																		
	W(width)		L(length)	Active area	View area																
	$W \leq 0.03$		ignored	ignored	ignored																
$0.03 < W \leq 0.05$	$L \leq 2.0$	3																			
$W > 0.05$	-	Not allowed																			



11. Reliability Test Items

Item	Test Condition	Criterion
High Temperature Storage	70 °C, 48 hrs	Note1,Note2
Low Temperature Storage	-20 °C, 48 hrs	
High Temp. & High Humidity Storage	40 °C, 80% RH, 48hrs	
Thermal Shock (Static)	-20°C, 30 min /70°C, 30 min, 20 cycles	
High Temperature Operation	60 °C, 48 hrs	
Low temperature Operation	-10 °C, 48 hrs	

Note1: Evaluation should be tested after storage at room temperature for two hours.

Note2:

Pass: Normal display image no line defect.

Fail: No display image, or line defects.

Partial transformation of the module parts should be ignored.

12. Precautions

Please pay attentions to the followings as using the LCD module.

Handling

- Do not apply strong mechanical stress like drop, shock or any force to LCD module. It may cause improper operation, even damage.
- Because the polarizer is very fragile and easy to be damaged, do not hit, press or rub the display surface with hard materials.
- Do not put heavy or hard material on the display surface, and do not stack LCD modules.
- If the display surface is dirty, please wipe the surface softly with cotton swab or clean cloth.



SPEC TITLE

DOCUMENT CONTROL SPECIFICATION

EFFECTIVE DATE : 2020-03-30

- (e) Avoid using Ketone type materials (e.g. Acetone), Toluene, Ethyl acid or Methyl chloride to clean the display surface. It might damage the touch panel surface permanently. The recommended solvents are water and Isopropyl alcohol.
- (f) Wipe off water droplets or oil immediately.
- (g) Protect the LCD module from ESD. It will damage the LSI and the electronic circuit.
- (h) Do not touch the output pins directly with bare hands.
- (i) Do not disassemble the LCD module.
- (j) Do not lift the FPC of Touch Panel.

Storage

- (a) Do not leave the LCD modules in high temperature, especially in high humidity for a long time.
- (b) Do not expose the LCD modules to sunlight directly.
- (c) The liquid crystal is deteriorated by ultraviolet. Do not leave it in strong ultraviolet ray for a long time.
- (d) Avoid condensation of water. It may cause improper operation.
- (e) Please stack only up to the number stated on carton box for storage and transportation. Excessive weight will cause deformation and damage of carton box.

Operation

- (a) When mounting or dismounting the LCD modules, turn the power off.
- (b) Protect the LCD modules from electric shock.
- (c) The Driver IC control algorithms stated above should always obeyed to avoid damaging the LSI and electronic circuit.
- (d) Be careful to avoid mixing up the polarity of power supply for backlight.
- (e) Absolute maximum rating specified above has to be always kept in any case. Exceeding it may cause non-recoverable damage of electronic components or, nevertheless, burning.
- (f) When a static image is displayed for a long time, remnant image is likely to occur.
- (g) Be sure to avoid bending the FPC to an acute shape, it might break FPC.
- (h) Most of the touch screens have air vent to equalize the inside air pressure to the outside one. The air vent must be open and liquid contact must be avoided as the liquid may be absorbed if the liquid is accumulated near the air vent.

- (i) For the fragility of ITO film, it should avoid to use too tapering pen as the input material.

Touch Panel Mounting Notes

- (a) If a cushion is used between bezel/housing and film must be choose as free as enough to absorb the expansion and contraction to avoid the distortion of film.
- (b) The cushion must be placed out of the Viewing Area.
- (c) Bezel/Housing edge must be posited between Key Area and Viewing Area. The edge enters the Key Area may cause unexpected input if the gap is too narrow or foreign particles like dusts exist between Bezel/Housing and ITO film.
- (d) Mounting example:

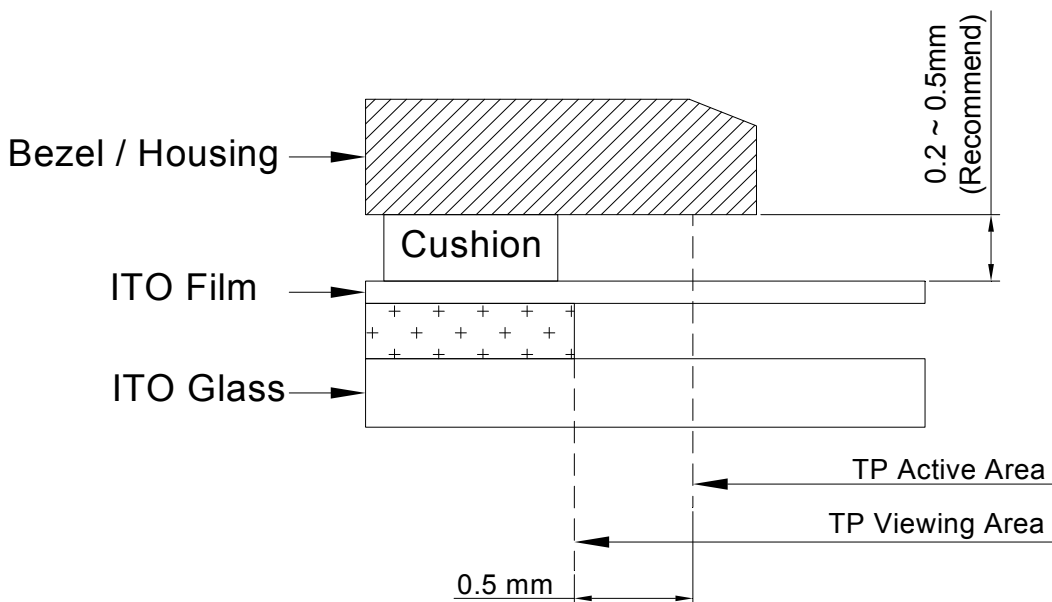

The corner part has conductivity. Do not touch any metal part after mounting.

Others

- a) If the liquid crystal leaks from the panel, it should be kept away from the eyes or mouth.
- b) For the fragility of polarizer, it is recommended to attach a transparent protective plate over the display surface.
- c) It is recommended to peel off the protection film on the polarizer slowly so that the electrostatic charge can be minimized.